

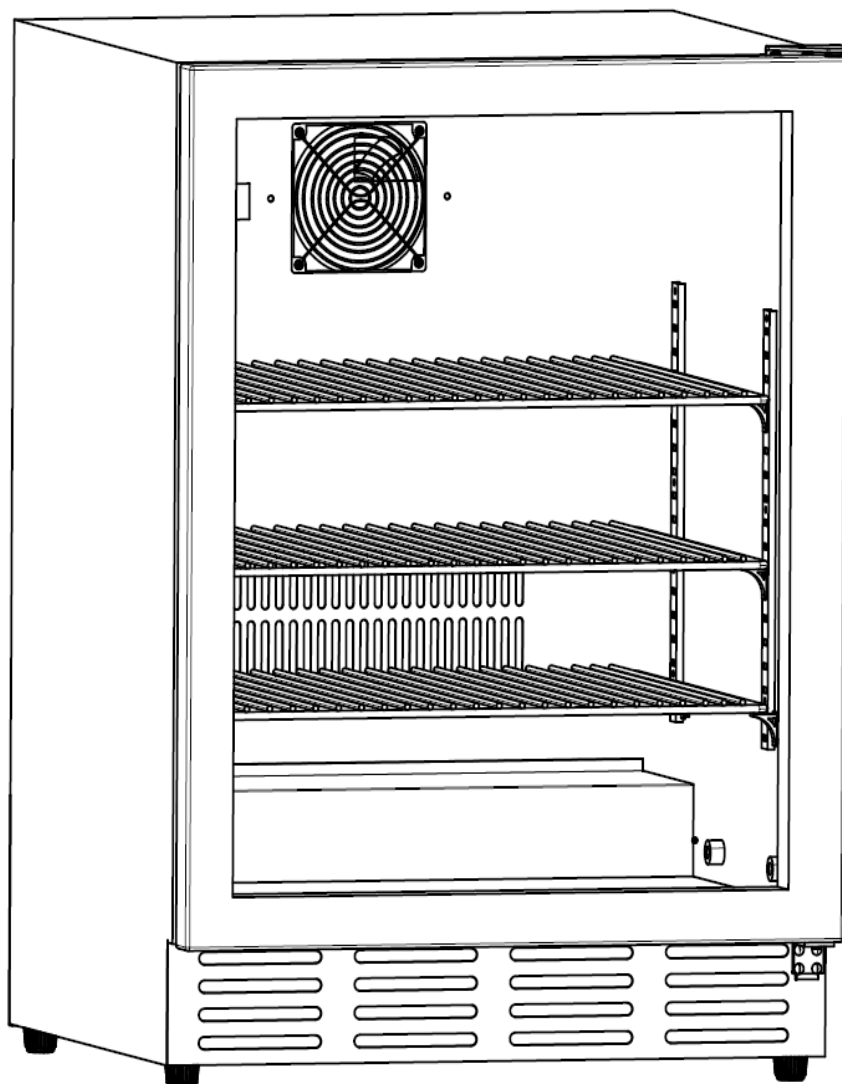

**PREMIUM OUTDOOR GLASS FRIDGE
#13100CE
OWNER'S MANUAL**



CE

Contents	Page #
Safety Information	3-5
Getting to know your Refrigerator	6
Installing your Refrigerator	7-9
Installation Requirments/ Unpacking	7
Levelling / Adjustable Feet/Door Lock/ Shelves	8
Defrosting / Alarm / Control Panel	9
Care and Maintenance	10-11
Product Support	12-13
Parts List	14
Exploded Illustrations	15
Warranty	16-17

- READ THE FOLLOWING INSTRUCTIONS CAREFULLY AND BE SURE YOUR APPLIANCE IS PROPERLY INSTALLED, ASSEMBELLED AND CARED FOR. FAILURE TO FOLLOW THESE INSTRUCTIONS MAY RESULT IN SERIOUS BODILY INJURY AND/OR PROPERTY DAMAGE. IF YOU HAVE QUESTIONS CONCERNING ASSEMBLY OR OPERATION, CONSULT YOUR DEALER, GAS APPLIANCE SERVICE REPRESENTITIVE OR YOUR GAS COMPANY.
- NOTE TO INSTALLER: LEAVE THESE INSTRUCTIONS WITH THE CONSUMER AFTER INSTALLATION.
- NOTE TO THE CONSUMER: RETAIN THESE INSTRUCTIONS FOR FUTURE REFERENCE.
- THIS APPLIANCE IS NOT INTENDED TO BE INSTALLED IN OR ON RECREATIONAL VEHICLES AND/OR BOATS.
- FOR WARRANTY PURPOSES, PLEASE RECORD YOUR MODEL NUMBER, SERIAL NUMBER, DATE OF PURCHASE & A COPY OF YOUR RECEIPT OR INVOICE IN THE BACK OF YOUR MANUAL ON PAGE 17.



 **Safety Information**

Important - Please read the instructions before installing or operating

WARNING: Keep ventilation openings in the appliance enclosure or the inside unit, clear of obstruction.

To ensure proper ventilation for your appliance, the front of the unit must be completely unobstructed. Leave at least 5cm clearance around the unit inside the structure. Choose a well ventilated area with temperatures above 10°C and 32°C.

WARNING: Do not use electrical appliances inside the storage compartments of the appliance unless they are of the type recommended by the manufacturer.

WARNING: Do not damage the refrigerant circuit.

WARNING: Due to the instability of the appliance, it must be fixed in accordance with the instructions to avoid a hazard.

WARNING: If the supply cord is damaged, it must be replaced by the manufacturer, its service agent or similarly qualified persons in order to avoid a hazard.

WARNING: The appliance is intended to be used in household and domestic applications only. Do not use the appliance for industrial and commercial use, or any other purpose.

WARNING: This product is not suitable for food storage and must not be used to store food inside.

WARNING: This appliance is to only be used for its intended purpose as described in this Instruction Manual.

- This appliance contains the coolant Isobutane (R600a), a natural gas which is environmentally friendly. Although it is flammable, it does not damage the ozone layer and does not increase the greenhouse effect. The use of this coolant has, however, led to a slight increase in the noise level of the appliance. In addition to the noise of the compressor, you might be able to hear the coolant flowing around the system. This is unavoidable, but does not have any adverse effect on the performance of the appliance.
- Care must be taken during the transportation and installation of the appliance that no parts of the cooling system are damaged. Leaking coolant can damage the eyes.
- In the event of any damage:
- Avoid open flames and anything which creates a spark.
- Disconnect from the mains.
- Air the room in which the appliance is located for at least an hour.



Safety Information

Important - Please read the instructions before installing or operating

- Whilst carrying and positioning the appliance care must be taken not to damage the cooler gas circuit at the rear of the appliance.
- The appliance should not be located next to ovens, grills or other sources of high heat.
- Do not store explosive substances such as aerosol cans with a flammable propellant within or in the vicinity of this appliance. The fumes can create a fire hazard or explosion
- The appliance is design for indoor use only and must be protected from rain moisture and extreme temperature variations.
- This appliance is not intended for outdoor use.
- If the socket and refrigerator plug are not compatible please contact after sales service provider.
- Before connecting the appliance, make sure that the connection data on the data plate (voltage and frequency), matches the mains electricity supply. This data must correspond in order to avoid the risk of damage to the appliance. Consult a qualified electrician if in any doubt.
- Ensure the accessories are secured during transportation to prevent damage.
- Do not splash water on the appliance. It may cause electrical parts to fail and result in an electric shock.
- Do not sit, stand or place any other heavy objects on top of the appliance. This could result in injury or damage to the appliance.
- To prevent possible harm to the environment or human health from uncontrolled waste disposal, recycle it responsibly to promote the sustainable reuse of material resources.
- This appliance can be used by children aged from 8 years and above and persons with reduced physical, sensory or mental capabilities or lack of experience and knowledge if they have been given supervision or instruction concerning use of the appliance in a safe way and understand the hazards involved. Children shall not play with the appliance. Cleaning and user maintenance shall not be made by children without supervision. Children aged from 3 to 8 years are allowed to load and unload refrigerating appliances.
- Young children should be supervised to ensure that they do not play with the appliance.
- Never allow children to operate, play with or crawl inside the appliance.
- Child entrapment and suffocation are not problems of the past. Junked or abandoned appliances are still dangerous, even if they will “just sit for a few days”.
- In case there is a flammable gas leak, open the window for air circulation and disconnect from the mains. Do not use the temperature controller. Otherwise, sparks may happen.
- Before discarding your old refrigerator:
 - Take off the doors
 - Leave the shelves in place so that children may not easily climb inside.



Safety Information

Important - Please read the instructions before installing or operating

Before using your appliance:

- Before switching on your appliance for the first time, ensure it is positioned in the desired final location and is in an upright position for at least 24 hours before plugging in and switching on the power, otherwise you may damage the compressor. It is important that the appliance be leveled in order to work properly. You may need to make several adjustments to level it.
- You may experience an odour from the appliance when it is operated for the first time. This is normal and will fade when your appliance starts to cool.
- It is recommended that you remove all the internal and external packaging and clean the interior of the appliance prior to first use. We recommend you wipe all parts with warm water, then rinse and dry. Place all parts back into the appliance after cleaning.

Read care and maintenance instructions on page 10 before cleaning



Warning: Risk of fire / flammable materials.

- When positioning the appliance, ensure that supply cord is not trapped or damaged.
- Do not locate multiple portable socket-outlets or portable power supplies at the rear of the appliance.
- To avoid contamination of drinks, pay attention to the following:
 - Opening the door for long periods of time can cause a significant increase in the temperature in the compartments
 - Only store wine in sealed container
 - Do not overload the cabinet
- Only open the door when necessary. Keep fingers out of the “pinch point” areas. Clearances between the door and cabinets between the door and cabinet are necessarily small. Be careful from the closing door when children are in the area.
- This appliance is intended to be used exclusively for the storage of wine.
- In the event of a power failure, leave the door closed as much as possible to maintain the internal working temperature. Should the power failure continue for a prolonged period, you should take steps to protect the contents of the wine cooler against a rise in temperature. The wine cooler will remember the selected temperature setting and revert to these settings once the power is restored.



GETTING TO KNOW YOUR REFRIGERATOR

YOU'LL BE UP AND RUNNING IN NO TIME

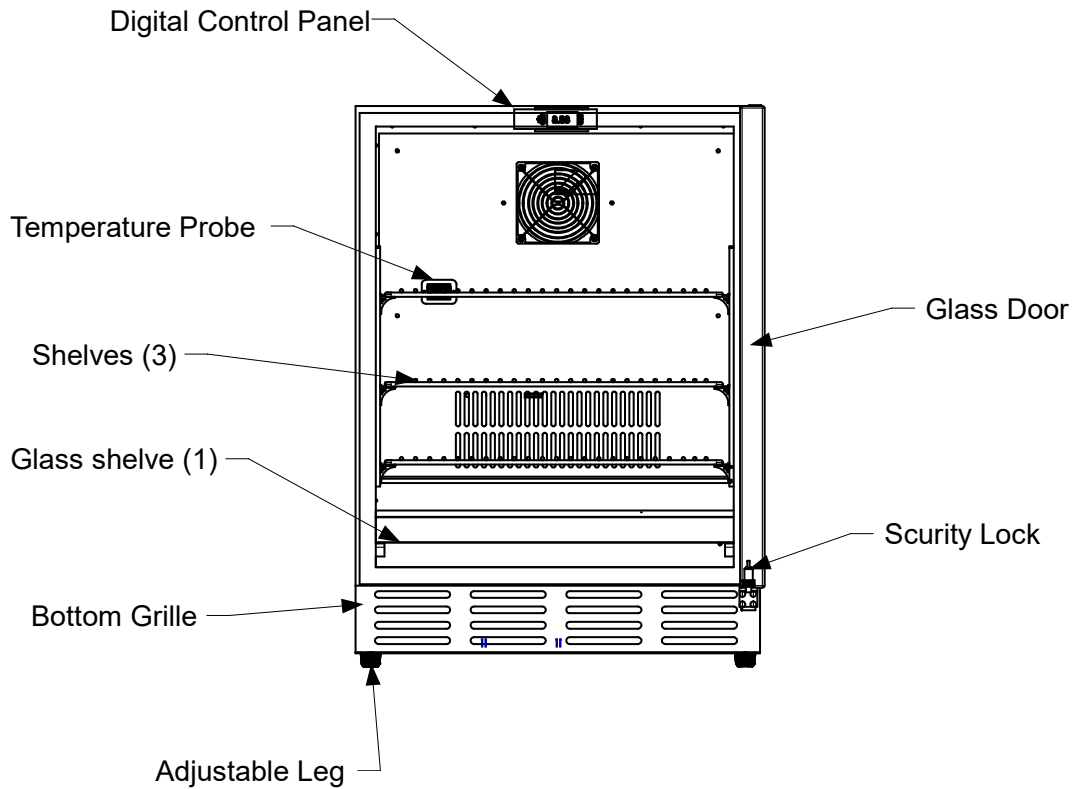

Technical Specification

Model	13100CE
Fridge Capacity	145L
Voltage and Frequency	220-240V AC/50Hz
Protection Class	I
Climate Class	N
Rated Current	0.9
Rated Lamp Power	1W
Refrigerant	R600a/25g
Size WxDxH	595x575x820



INSTALLING YOUR REFRIGERATOR

BRINGING IT ALL TOGETHER

Installation requirements

Before starting to use your refrigerator, you should pay attention to the following points:

- Use two or more people to move and install the appliance. Failure to do so can result in back pain or other injury.
- The appliance must be installed with all electrical, water and drain connections in accordance with state and local codes. A standard electrical supply properly grounded in accordance with the National Electrical Code and local codes and ordinances is required. Operating voltage for your refrigerator is 220-240V at 50Hz.
- It is recommended that a separate circuit serving only your appliance is to be provided. Use receptacles that cannot be turned off by a switch or pull chain.
- We do not take responsibility of the damages that occur due to ungrounded usage.
- Do not place your appliance in direct sunlight.
- Your appliance should be at least 50 cm away from stoves, Gas ovens and heaters, and should be at least 5cm away from electrical ovens.
- Your refrigerator should never be used outdoors or left out in the rain.
- When your refrigerator is placed next to a deep freezer, there should be at least 2cm between them to prevent humidity or the outer surface.
- Do not place anything on your fridge. Install your refrigerator in a suitable place so that there is at least 10 mm clearance on top.
- Make certain that the pipes are not pinched, kinked or damaged during installation.
- Before using your refrigerator, wipe all parts with warm water, and then rinse and dry. Place all parts back in the appliance after cleaning.
- This appliance should be placed against a wall with a free distance of at least 30mm.
- Dispose of all packaging carefully and responsibly.
- The appliance is designed for indoor use only and must be protected from rain, moisture and extreme temperature variations.
- This appliance is designed for household use. Do not use the appliance for industrial and commercial use, or any other purpose.
- The appliance **MUST** be positioned on a firm level base.
- Ensure a minimum 5cm clearance around all sides of the refrigerator for proper ventilation.
- Check for leaks after connection.

Unpacking

- Please make sure that when unpacking your appliance it is carried out in a safe manner.
- Ensure the packaging is disposed of in accordance to local regulation
- Do not allow children to play with the packaging material, e.g. plastic bags and wrappings. **Danger of Suffocation.**



INSTALLING YOUR REFRIGERATOR

Levelling Feet

BRINGING IT ALL TOGETHER

- The appliance must be installed level in order to work properly. If the unit is not level, the doors and magnetic seal alignment will not be covered properly.
- To level the unit, adjust one or both leveling feet at the base of the unit.

Adjustable Feet

This appliance comes with height adjustable feet which allows the appliance to be installed under bench and ensures the appliance is stable and level. Just screw the bottom feet anticlockwise to raise the height up to 880mm or clockwise to lower the height to 820mm. See the photos below.

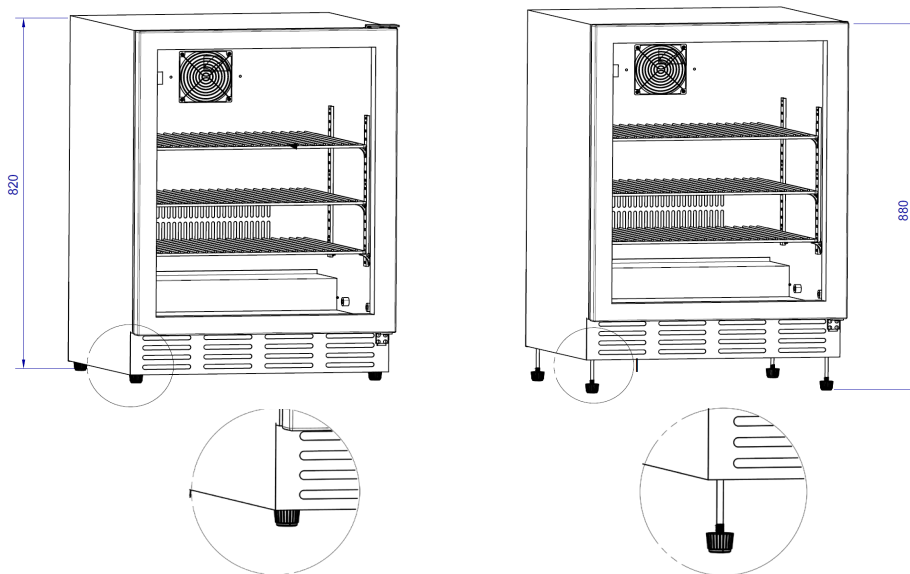

Door Lock

Your Unit is provided with a lock and key combination. The keys are located inside the plastic bag that contains the Instruction Manual. To lock the door insert the key into the lock and turn it clockwise. To unlock the door turn it anti-clockwise, making sure that the metal pin is engaged completely. Remove the key and keep it in a secure place for safekeeping.

Shelves

To prevent damaging the door gasket, make sure to have the door all the way open when pulling the shelves out of the shelf-supports. Any of the shelves can be removed to store larger items. When removing the shelf out of the shelf-supports, make sure to remove all items first.

Defrosting

The refrigerator is designed to defrost automatically every 4 hours. The defrost process will last for 20 minutes. During defrost, the compressor stops working and fan keeps on running for 20 minutes.

Door Alarm

The refrigerator is equipped with an alarm that will sound if the door is open for more than 60 seconds. Close the door or press any key once to switch off the alarm.



OPERATING YOUR APPLIANCE

Help is Always at Hand

It is recommended that you install the appliance in a place where the ambient temperature is between 10°C and 32°C. If the ambient temperature is above or below recommended temperatures, the performance of the unit may be affected. For example, placing your unit in extremely cold or hot conditions may cause interior temperatures to fluctuate. The operating temperature range may not be reached.

Control Panel

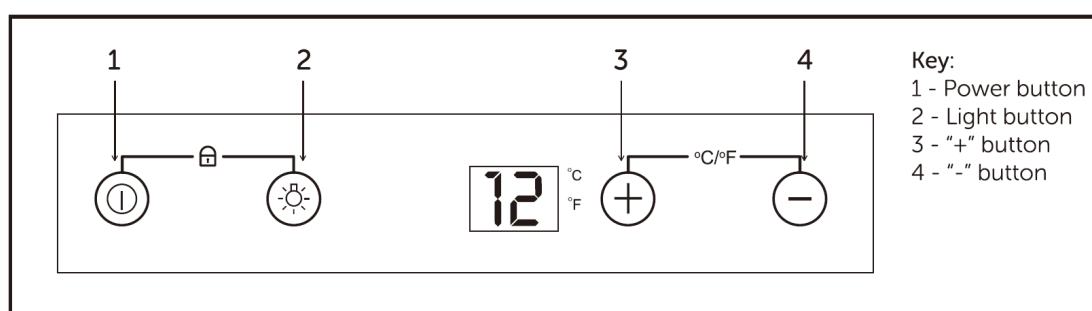



ON/OFF Power

To turn the appliance ON or OFF, press and hold the POWER key  for 5 seconds

Interior Light

Press  to switch ON or OFF the light. The light will automatically re-activate next time the door is opened.

Lock Feature

Press and hold the  and the  for 1 second to lock the control panel. This will make any feature locked and unable to be changed until you do the same action again to un-lock the control panel.

UP + and DOWN -

Press + or - to increase (warm) or decrease (cool) the set temperature by 1°C/1°F

°C/°F Selector

Selects the temperature display setting in Fahrenheit or Celsius degrees. To change the temperature from Fahrenheit to Celsius or from Celsius to Fahrenheit, press and hold the + and the - at the same time for 3 seconds.

Setting the Temperature Control

The temperature you are setting will increase by one degree each time you press the + key and will decrease by one degree each time you press the - key.

The range of the temperature control is from -0°C to 22°C.

For Tips, please see the “” symbol on control panel.



CARE AND MAINTENANCE

LOOKING AFTER YOUR APPLIANCE

Cleaning your appliance

- Make sure you unplug the appliance or disconnect power before cleaning or servicing. Do not connect or disconnect the electric plug when your hands are wet. Failure to do so may result in electric shock or death.
- Do not pour water directly over your appliance.
- You can wipe the inner and outer sides with a soft cloth.
- Remove parts individually and clean by hand with soapy water. Do not place in dishwashers.
- Never use flammable, explosive or corrosive material for cleaning your appliance.
- Clean the dust behind the appliance and on the ground to improve the cooling and energy saving.
- The interior of the cooler should be cleaned regularly to avoid odor.
- Check the door gasket regularly to make sure there are no debris. Clean with mild soap and water
- Use a soft cloth or sponge to clean the inside of the cooler, with two tablespoons of baking soda and a litre of warm water. Then rinse with water, wipe clean, open the door and dry it naturally, before the power is turned on.
- Do not use soap, detergent, scrub powder, spray cleaner, etc, as these may cause odors or damage the interior of the appliance.
- Clean the bottle frame and shelves with a mild detergent and dry with a soft cloth.
- Wipe the outer surface of the cooler with a soft cloth dampened with soapy water, detergent, etc., and then wipe dry with a clean soft cloth.
- Do not use hard brushes, steel wool, wire brushes, abrasives, or solvents like, alcohol or acetone, boiling water, acids or alkaline to clean this appliance, as it may damage or deform the surface or interior.
- Do not rinse with water so as not to affect the electrical insulation properties.
- Do not attempt to repair or replace any part of your appliances unless it is specifically recommended in this manual. All other servicing should be referred to a qualified technician.

Light Bulb Replacement

The internal light is a LED type. To replace the lamp, please speak to after sales service provider.

Power Failure

If the power failure lasts for up to 24 hours, keep the door closed. This will allow the stored bottles to stay cold as long as possible. If it lasts longer than 24 hours, it is advised to empty the appliance and temporarily store the bottles in a portable appliance.

Short vacation

There is no need to disconnect the appliance from the mains if you will be away for two to three weeks.

Long vacation

Remove all the contents if you are away for three weeks or more. Unplug the appliance and leave the doors open to provide air circulation to prevent odour and mould.

If the refrigerating appliance is left empty for long periods, switch off, defrost, clean, dry, and leave the door open to prevent mould developing within the appliance.



CARE AND MAINTENANCE

LOOKING AFTER YOUR APPLIANCE

Moving your Appliance

- Remove all items.
- Securely tape down all loose items (shelves) inside your appliance.
- Turn the adjustable legs up to the base to avoid damage.
- Tape the door shut.

Be sure the appliance stays secure in the upright position during transportation. Also protect the outside of the appliance with a blanket or similar item.

MAKE SURE YOU HAVE READ THE SAFETY INSTRUCTIONS

Energy Saving Tips

The appliance should be located in the coolest area of the room or outdoor location, away from heat producing appliances and out of direct sunlight. Ensure that the unit is adequately ventilated. Never cover air vents. Do not keep the door open any longer than necessary. Let hot foods cool to room temperature before placing in the unit. Overloading the unit forces the compressor to run longer. Be sure to wrap foods properly, and wipe containers dry before placing them in the unit. This cuts down on frost build up inside the unit. Unit shelves and storage bins should not be lined with aluminum foil, wax paper or paper toweling. Liners interfere with cold air circulation, making the unit less efficient. Organize and label stored items to reduce door openings and extended searches. Remove as many items as needed at one time, and close the door as soon as possible.



Product Support

Trouble Shooting

Help is Always at Hand

Problem	Possible Cause	Solution
The doors do not close properly	<ul style="list-style-type: none"> Unable to close the door due objects in the way. The door and shelves are not placed in properly causing a blockage. The door seal is warped or torn. The door seal is dirty. The appliance is off balance. 	<ul style="list-style-type: none"> Ensure there are no obstructions preventing door closure. Check the door and shelves are correctly in place. Check the door seal is not warped or torn. Clean the door seal. Level the appliance with adjustable the feet.
Unusual Noises	<ul style="list-style-type: none"> The appliance is not properly level. Contraction and expansion of the inside walls may cause popping and cracking noises. The rattling noise may come from the flow of the refrigerant, which is normal. As each cycle ends, you may hear gurgling sounds caused by the flow of refrigerant in your appliance. If temperature fluctuations occur, the contraction and expansion of the inner walls may cause popping and cracking noises. 	<ul style="list-style-type: none"> Set the appliance on a flat, level surface or level with the adjustable feet. Check the spacing's around the appliance and ensure it is not touching other items. Bubbling and gurgling sound: This noise is emitted as the coolant fluid flow through the pipes within the system. This is normal. Allow the fridge to settle and this will stop the noises shortly after
The cooler door will not open	<ul style="list-style-type: none"> Warm air entered the fridge and causes a vacuum The door was closed too quickly creating a vacuum 	<ul style="list-style-type: none"> If the door has just been opened, leave it for a few minutes to allow the air pressure to equalise before trying again.
The compressor runs constantly/frequently	<ul style="list-style-type: none"> The temperature is set too cold The Fridge door was left open The room/area is too warm. The door was opened an excessive amount of times. 	<ul style="list-style-type: none"> Select a lower (warmer) setting. Ensure that the door is closed properly. Place the appliance in a cooler place. Avoid opening the door unless necessary.
The external fridge surface is warm	<ul style="list-style-type: none"> This is normal, due to the compressor doing its job 	<ul style="list-style-type: none"> The exterior walls can be warmer than room temperature. This is normal while the compressor works to transfer heat from inside the bottle cabinet.
Smells / Odours	<ul style="list-style-type: none"> Expired or exposed food or drinks 	<ul style="list-style-type: none"> Check for spillages through the cooler. Spillages may cause odours if left unwashed. Wash accordingly to the manufacturers advise.



Product Support

Trouble Shooting

Help is Always at Hand

Problem	Possible Cause	Solution
Appliance does not Operate	<ul style="list-style-type: none"> • Appliance is not connected to a power supply. • The appliance is turned off. • Tripped circuit breaker or a blown fuse. 	<ul style="list-style-type: none"> • Connect the appliance. • Switch on the appliance. • Switch on circuit breaker or replace fuse.
Appliance is not cold enough	<ul style="list-style-type: none"> • The temperature is not set correctly. The ambient temperature could require a lower temperature setting. • The door was opened an excessive amount. • The door was not closed properly. • The door is not hermetically sealed. • The condenser is too dirty. The ventilation opening is blocked or too dusty. 	<ul style="list-style-type: none"> • Set a lower temperature • Do not open the door unless necessary. • Ensure the door is enclosed well. • Check the door seal and clean or replace. • Clean the condenser when necessary. Clear the obstructions and clean the dust.
Appliance turns itself off and on frequently	<ul style="list-style-type: none"> • The room temperature is higher than average. • A large amount of food has been added to the unit • The door is opened an excessive amount. • The door is not closed completely. • The door gasket does not seal properly. 	<ul style="list-style-type: none"> • Put the appliance in a cooler place. • Leave the appliance to work for a while until the set temperature has been reached. • Do not open the door more often than necessary. • Close door properly. • Check the door seal and clean or replace.
The light does not work	<ul style="list-style-type: none"> • Appliance is not connected to a power supply. • The light was switched off on the control panel. 	<ul style="list-style-type: none"> • Connect the appliance. • Switch on the light.
Vibrations	The appliance is not properly leveled.	<ul style="list-style-type: none"> • Level the appliance with the adjustable feet.
The alarm sounds and the temperature display flashes	<p>Has the appliance door been open for longer than 60 seconds? If not, then the temperature has risen higher or fallen lower than the temperature that has been set. This could be due to:</p> <ul style="list-style-type: none"> • The appliance door being opened too often. • The ventilation opening being covered or too dusty. • A lengthy interruption in the power supply. • A large amount of food has been added to the unit. 	<ul style="list-style-type: none"> • If yes, close the door. • Do not open the door more often than necessary. • Clear up any dust or blockages. • Restart the fridge and follow the step below • Leave the appliance to work for a while until the set temperature has been reached.



Parts List

Ref #	Part Number	Item	Qty	Warranty
1	13103	Right Top Door Hinge	1	2 Years
2	13115	Shelves	3	2 Years
3	13706	Shelf Ladder	4	2 Years
4	13704	Shelf Clips	6	2 Years
6	13708	Glass Shelf	1	2 Years
7	13106	Thermostat Sensor Cover	1	2 Years
8	13105	Fan Channel Pannel	1	2 Years
9	13107	Evaporator Fan Cover	1	2 Years
10	13109	Control Box	1	2 Years
11	13104	Evaporator Fan	1	2 Years
12	13120	Adjustable Feet	4	2 Years
13	13116	Door Lock	1	2 Years
14	13117	Lower Door Axes	1	2 Years
15	13113	Stainless Steel Glass Door	1	2 Years
16	13101	Cabinet	1	2 Years
17	13124	Kick Plate	1	2 Years
18	13114	Door Gasket	1	2 Years
19	13126	Fan Motor	1	2 Years
20	13131	Compressor	1	2 Years
21	13128	Compressor Chamber Cover	1	2 Years



Exploded View

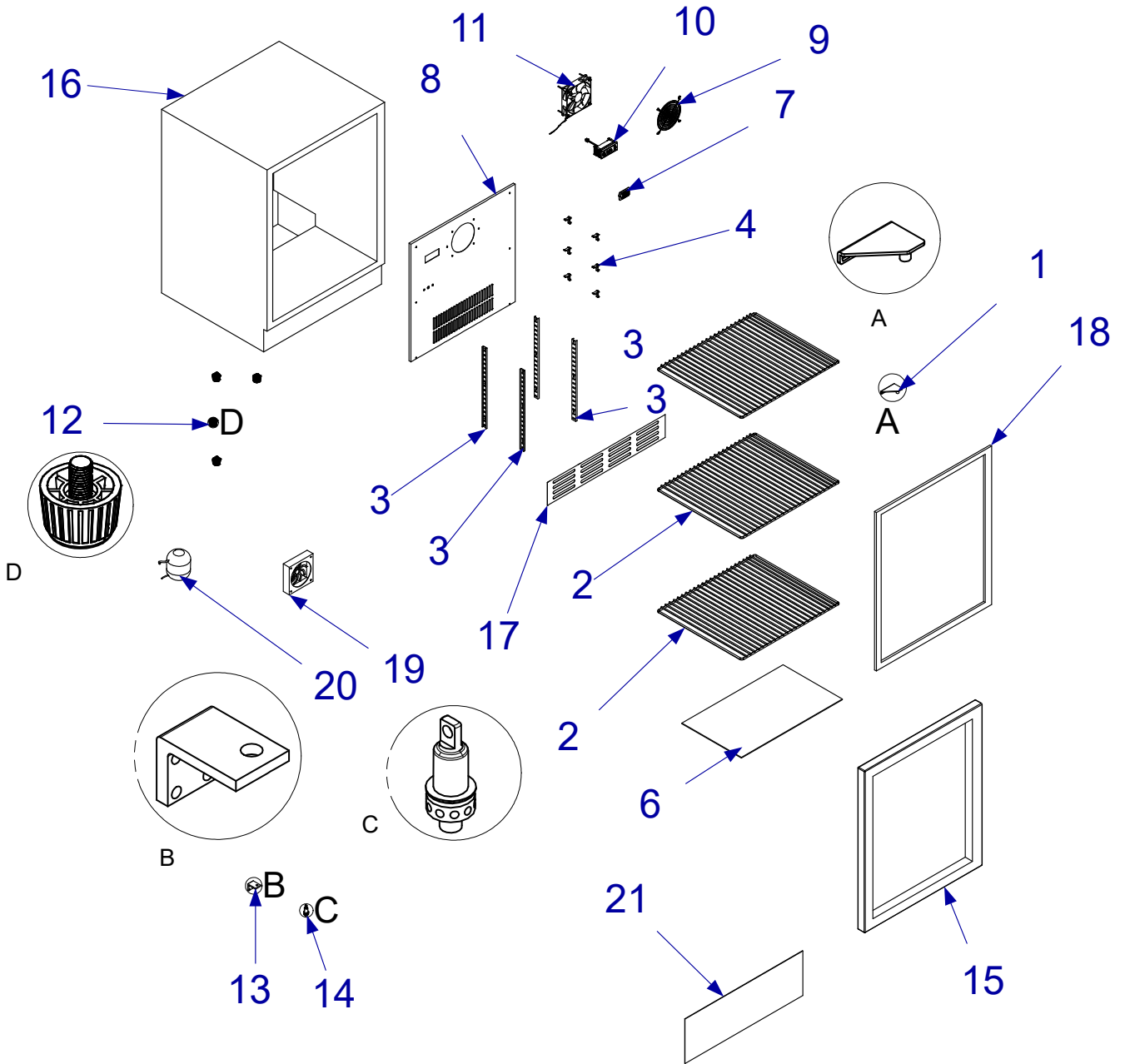

WARRANTY POLICY

LIMITED WARRANTY ON BULL OUTDOOR PRODUCTS, INC., PRODUCTS

THIS LIMITED WARRANTY GIVES YOU SPECIFIC LEGAL RIGHTS. YOU MAY ALSO HAVE OTHER RIGHTS, WHICH VARY FROM COUNTRY TO COUNTRY.

This limited warranty can also be found on our web site at: www.bullbbq.eu/en/warrantyform.htm and in the owner's/ installation manual that we provide with our product.

This limited warranty is subject to the exclusions, conditions and limitations set forth below.

Any implied warranties imposed by law, including without limitation the implied warranties of merchantability and fitness for a particular purpose, are limited in duration to the duration of this express limited warranty. Some countries do not allow limitations on how long an implied warranty lasts, so the above limitation may not apply to you.

WHO MAY USE THIS WARRANTY?

BULL OUTDOOR PRODUCTS, INC. located at address 1011 East Pine St. Lodi, CA. 95240 ("we") extend this limited warranty only to the consumer who originally purchased the product ("you") at the original site of delivery or installation. It does not extend to any subsequent owner or other transferee of the product. It does not apply to products installed in any rental, commercial or non-residential application. Examples of excluded applications include, but are not limited to day care centers, schools, bed and breakfast centers, churches, private clubs, fire stations, club houses, common areas in multi-family dwellings, restaurants, hotels, nursing homes, food service locations and institutional food service locations.

WHAT DOES THIS WARRANTY COVER?

This limited warranty covers defects in materials and workmanship of the product and product components identified below for the Warranty Periods defined below.

WHAT IS THE PERIOD OF COVERAGE?

This limited warranty starts on the date of your purchase and lasts for the time period or time periods specified above (the "Warranty Period"). The Warranty Period is not extended if we repair or replace the product. We may change the availability of this limited warranty at our discretion, but any changes will not be retroactive.

WHAT DOES THIS WARRANTY NOT COVER?

This limited warranty does not cover any damage due to: (a) transportation; (b) storage; (c) improper installation or use; (d) use on improper fuel/gas supply; (e) failure to follow the product instructions or to perform any preventive maintenance; (f) modifications; (g) unauthorized repair; (h) normal wear and tear; or (i) external causes such as accidents, abuse, or other actions or events beyond our reasonable control.

WHAT ARE YOUR REMEDIES UNDER THIS WARRANTY?

With respect to any defective product claim made during the Warranty Period, we will, in our sole discretion, either: repair or replace such product (or the defective part) free of charge or (b) refund the purchase price of such product. We will not pay for shipping charges for repaired or replacement parts, or for any labor or labor related charges. We will not pay for any accessory products or ancillary products purchased by you for use in connection with the product.

HOW DO YOU OBTAIN WARRANTY SERVICE?

To obtain warranty service, you must submit a warranty claim via email to aftersales@bullbbq.eu during the Warranty Period. Warranty claims will not be accepted via fax or phone.

LIMITATION OF LIABILITY

THE REMEDIES DESCRIBED ABOVE ARE YOUR SOLE AND EXCLUSIVE REMEDIES AND OUR ENTIRE LIABILITY FOR ANY BREACH OF THIS LIMITED WARRANTY. OUR LIABILITY SHALL UNDER NO CIRCUMSTANCES EXCEED THE ACTUAL AMOUNT PAID BY YOU FOR THE DEFECTIVE PRODUCT, NOR SHALL WE UNDER ANY CIRCUMSTANCES BE LIABLE FOR ANY CONSEQUENTIAL, INCIDENTAL, SPECIAL OR PUNITIVE DAMAGES OR LOSSES, WHETHER DIRECT OR INDIRECT. SOME STATES DO NOT ALLOW THE EXCLUSION OR LIMITATION OF INCIDENTAL OR CONSEQUENTIAL DAMAGES, SO THE ABOVE LIMITATION OR EXCLUSION MAY NOT APPLY TO YOU.



WARRANTY POLICY

Grill Warranty Periods:

The following parts are covered for two years on all our current gas grill models:

The lid, control panel, grease tray, bezels, knobs, temperature gauge, valves, regulator, flex tubes, rotisserie burner, transformer, and all components of the lighting system.

The following parts are covered for three years on all our current gas grill models:

The manifold, handle end caps, flame tamers, heat shields, and warming rack.

The following parts are covered for 20 years on all our current gas grill models:

Insert assembly and the grates.

The warranty period for the grill burners vary by type:

- Cast stainless steel burners – 20 years,
- Welded burners – 5 years, and
- Porcelain coated burners – 3 years.

The warranty period for the charcoal grill is two years on all parts, except for the insert assembly, which is covered for 5 years. Component Warranty Periods:

All of the parts for our components/grill carts/refrigerators/kegerators/drawers/doors are covered for two years with these exceptions:

Searing Station/Slide in Double Sideburner/ Slide in Pro Sideburner

- The grates are covered for lifetime, the insert for 5 years, and the manifold for 3 years.

Single Sideburner

- The grates are covered for 5 years and the burner for 3 years.

SidekickSideburner

- The burner is covered for 3 years.
- Pizza Ovens/Islands/Fire Features Warranty Periods

All of the parts and construction materials are covered for two years.

Grill Accessories and Grill Covers do not include a warranty period.

Registering your Grill

Thank you for purchasing your Bull Outdoor Product. To validate your Limited Warranty, you must submit the completed the Warranty Registration Form within 90 days from the date of purchase. Registration can be completed on-line at: bullbbq.eu/en/warrantyform.htm or by sending the completed Warranty Registration Form and copy of your Purchase Receipt or Invoice as proof of purchase to: AfterSales@Bullbbq.eu

For Warranty Claims or Replacement Parts ordering, please fill out the area provided below:

PRODUCT INFORMATION REFERENCE CARD

- 1) Model # _____
- 2) Serial # _____
- 3) Date of Purchase _____
- 4) Copy of your Purchase Receipt or Invoice.

